



### 1220 Dafne

**CORPO:** In nylon f.v. infrangibile ed autoestinguente.  
**PORTALAMPADA:** In ceramica e contatti argentati. Attacco E27.  
**CABLAGGIO:** Alimentazione 230V/50 Hz.  
**EQUIPAGGIAMENTO:** Completo di basetta e puntale per l'interramento.  
**MONTAGGIO:** A parete o a terra.  
**NORMATIVA:** Sono prodotte in conformità alle vigenti norme EN60598-1 CEI 34-21 e sono protette con il grado IP65IK08 secondo le EN60529. In classe di isolamento II.  
**POTENZA LAMPADE:** PAR 80/120.

**Download**

DXF 2D  
- 1220dfn.dxf

Montaggi  
- dafne2.dxf  
- 1220\_dafne.pdf  
- dafne1.dxf

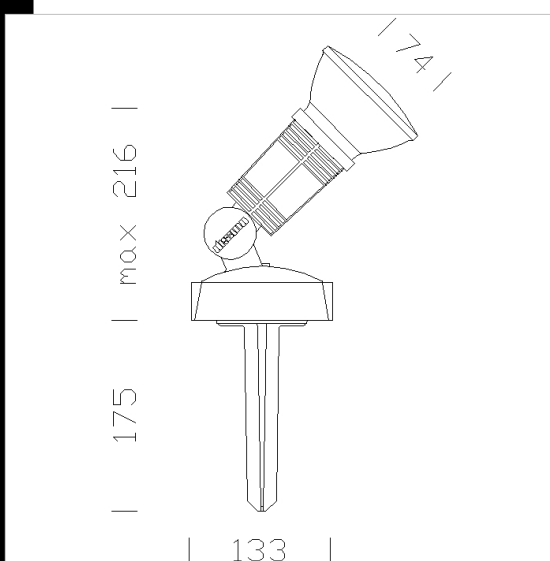

Code	Gear	Kg	Watt	Base	Lamps	Colour
431801-00	S	0,38	PAR 80/120	E27	1226lm-2700K-Ra 1b	NERO

**Accessori**



- 118 Morsetto



- 116 Supporto angolare



- 120 Supporto a palo